

REVISION HISTORY			
REV.	DESCRIPTION	DATE	DRAWN BY
1	ORIGINAL PRINT	12/2/2024	N. MASSOUDA

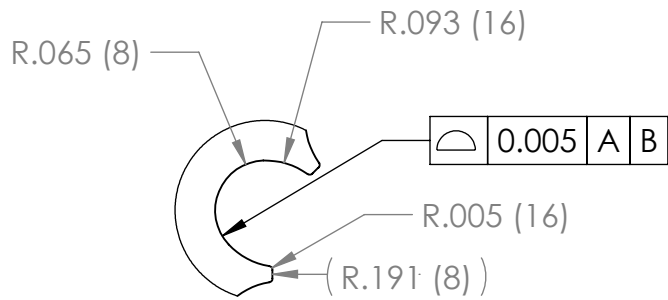

DETAIL A
SCALE 4 : 1

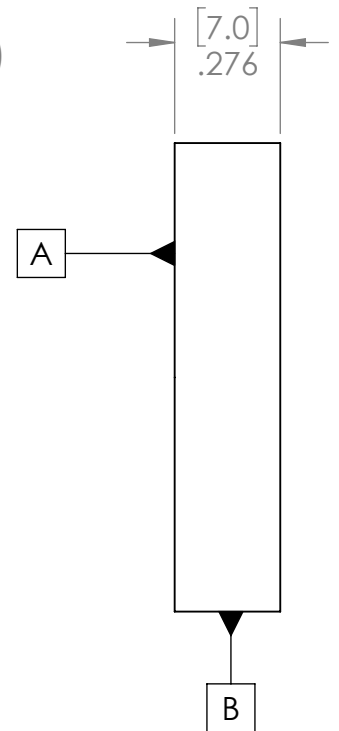
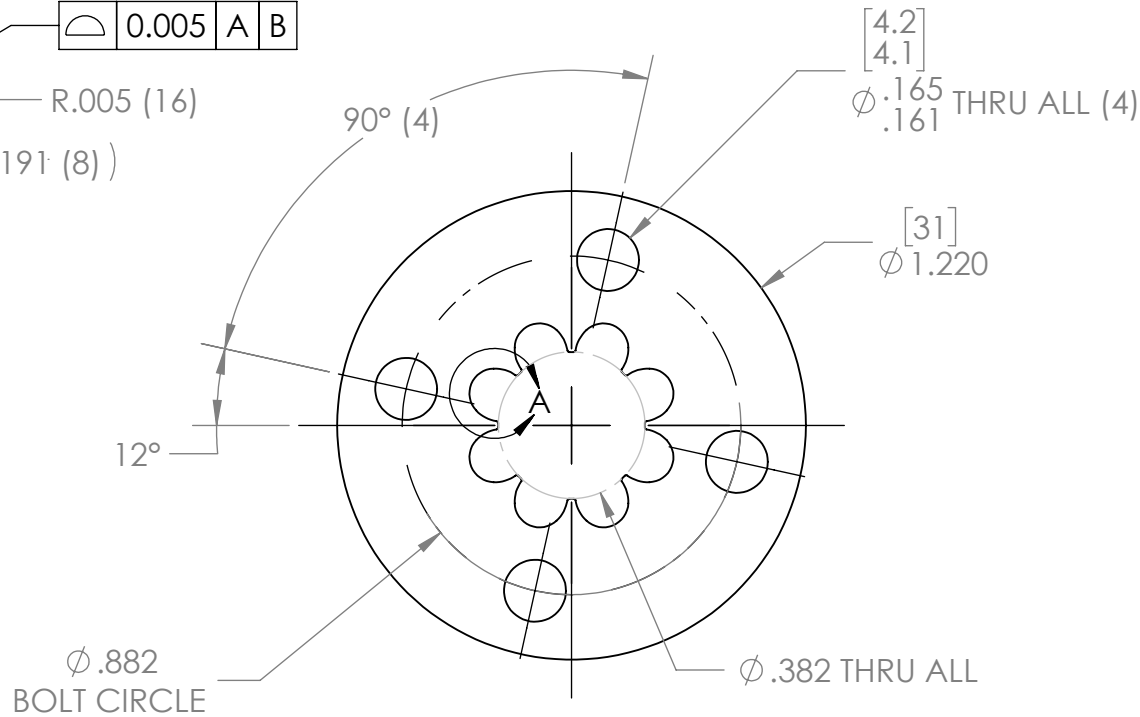

*** SEE CAD FOR ADDITIONAL TOOLPATH INFO***

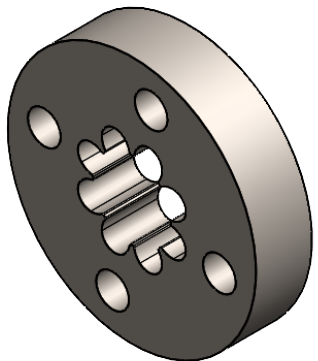

UNLESS OTHERWISE SPECIFIED:		COMMENTS:				
DIMENSIONS ARE IN INCHES		DUAL DIMENSIONS ARE IN MILLIMETERS.				
TOLERANCES:		BREAK ALL SHARP EDGES		TITLE:		
FRACTIONAL	±1/16			SPORT GEARBOX		
ANGULAR: MACH	±1°			1:1 INPUT PLATE		
ANGULAR: BEND	±5°			SIZE	DWG. NO.	REV
ONE PLACE DECIMAL	±0.1			A	am-5590	1
TWO PLACE DECIMAL	±0.01			SCALE: 2:1 WEIGHT:		
THREE PLACE DECIMAL	±0.005			SHEET 1 OF 1		
FOUR PLACE DECIMAL	±0.0005					
MATERIAL	4140 STEEL	CHECKED	NAME	DATE		
FINISH	DEBURRED	ENG APPR.	PY	12/3/24		
	ZINC PLATED	MFG APPR.				
DO NOT SCALE DRAWING		Q.A.				